

Vertical Form-Fill-Seal Machines
Macchine Confezionatrici Verticali



Series/Serie
C95e

The new intermittent Vertical F/F/S Machines Series C95e acquire important technological updates, derived from the continuous experience matured in the sector.

BENEFITS

- Extremely flexible on bag sizes and package styles
- Top performance and reliability
- Ease of operation and quick change over and setup
- Minimal maintenance and easy cleaning

TECHNICAL FEATURES

- Sturdy, light and compact frame, made in tubular painted steel white RAL 9003 (standard colour)
- Parts in contact with the product made in AISI 304 s.s. (optional 316)
- Cross sealing jaws movement by means levers system with “brushless” servo-motor
- Pre-setting of the jaws working to allow maximum speed
- Self-centring film pulling belts with independent motorization driven by “inverter”
- Motorized film reel holder with air expanding shaft and end-of-reel device, set on adjustable trolley
- Easy manual film splicing device
- Tool free film-roll and forming tube change over
- Electric box mounted on hinges to allow total access to the inside of the machine
- Modular, non-proprietary components
- **Operator’s panel 10” LCD color touch-screen with integrated temperatures control and wide range of communication ports**
- **More than 100 working programs memorization**
- Working: electro-pneumatic
- **Conforms to EEC standards**

PRODUCTS THAT CAN BE PACKAGED

In bulk:

Dry fruits, legumes, dry mushrooms, biscuits, baked products, candies, popcorn, chips, snacks, short pasta, mozzarella, frozen products and vegetables, small metals and plastic items, spare parts, etc.

Flowing products, powders and liquids:

Ground coffee, coffee beans, cocoa, rice, sugar, semolina, salt, pepper, seeds, granular products, pudding, milk in powder, spices, potato starch, different kinds of flours, plant loam, detergents, plaster, chemical additives, milk, water, etc.

WRAPPING MATERIALS

Heat-sealable films, various complex films, polyethylene, etc.

ACCESSORIES

Photocell for print centring, Various kinds of printing unit, Square bottom and gussets forming device, Sealing system for PE, Product settling devices, Gas injection device (MAP), Clip-band applicator, Valve applicator, Euroslot or handle forming device, Automatic film centring system, “Stabilo-bag” forming unit, Special sealing bars, Tele-service, etc.

DOSING SYSTEMS

Multiheads weighers, Linear weighers, Volumetric cups dosers, Auger filler dosers, Dosers for liquids, Counters, etc.

SPECIAL VERSIONS

- Mod. C95ei: inclined models for fragile products
- Mod. C95e INOX: stainless steel models
- Mod. C95e SV: for to pack granular products undervacuum
- **Mod. C110: pulling-film system with 2 brushless “servo-motors” and vacuum belts**



Le nuove Macchine Confezionatrici Verticali intermittenti Serie C95e acquisiscono importanti aggiornamenti tecnologici, derivati dalla continua esperienza maturata dalla Campagnolo nel settore.

VANTAGGI

- Grande flessibilità per l'ottenimento di diverse dimensioni e forme di sacchetto
- Prestazioni e affidabilità al top
- Semplicità d'uso e cambio formato
- Ridotta manutenzione e facilità di pulizia

CARATTERISTICHE TECNICHE

- Struttura robusta, leggera e compatta, costruita in tubolare di acciaio verniciato bianco RAL 9003 (versione standard)
- Parti a contatto col prodotto in acciaio inox AISI 304 (optional 316)
- Movimento delle barre saldanti orizzontali con sistema a leve azionato da servo-motore "brushless"
- Settaggio del movimento barre saldanti orizzontali, per consentire di ottimizzare la velocità produttiva
- Traino film con cinghie gommate autocentranti e motore indipendente controllato da "inverter"
- Carrello porta-bobina con albero espandibile pneumatico motorizzato e allarme fine-film
- Sistema per agevolare la giunzione manuale del film durante il cambio bobina
- Montaggio della bobina-film e cambio formato senza l'utilizzo di utensili
- Quadro elettrico montato su cerniere per facilitare l'accesso all'interno macchina
- Utilizzo di componentistica meccanica, pneumatica ed elettrica, standard e di qualità
- **Pannello operatore con schermo tattile a colori da 10", con integrato il controllo delle temperature ed ampia dotazione di porte di comunicazione**
- **Più di 100 ricette memorizzabili**
- Funzionamento: elettro-pneumatico
- **Conforme alla normativa CEE**

PRODOTTI CONFEZIONABILI

Alla rinfusa

Frutta secca, legumi, funghi essiccati, biscotti, prodotti da forno, caramelle, popcorn, chips, snacks, paste alimentari corte, mozzarelle, verdure e altri prodotti surgelati, minuterie metalliche e in plastica, parti di ricambio, ecc.

Scorrevoli, polveri non scorrevoli e liquidi:

Caffè in grani e macinato, cacao, riso, zucchero, semolina, sale, pepe, sementi, prodotti granulari vari, budini, latte in polvere, spezie, fecola di patate, farine varie, terriccio per fiori, detersivi, prodotti chimici, latte, acqua, ecc.

MATERIALI D'INCARTO

Film termosaldanti, Film accoppiati vari, Polietilene, ecc.

ACCESSORI

Fotocellula per centratura stampa, Stampatori di vario genere, Dispositivo formazione fondo piatto/soffietti, Sistema saldatura per film PE, Dispositivi assestamento prodotto, Dispositivo iniezione gas (MAP), Dispositivo applicazione clip-band, Dispositivo applicazione valvola, Dispositivo formazione "euroslot" o maniglia, Dispositivo centraggio film automatico, Gruppo formazione sacchetto "stabilo", Barre saldanti speciali, Tele-assistenza, ecc.

SISTEMI DI DOSAGGIO

Dosatori ponderali multiteste, Dosatori ponderali lineari, Dosatori volumetrici a tazze, Dosatori volumetrici a coclea, Dosatori volumetrici per liquidi, Contapezzi, ecc.

VERSIONI SPECIALI

- Mod. C95ei: modelli inclinati per prodotti fragili
- Mod. C95e INOX: modelli in acciaio inox AISI 304
- Mod. C95e SV: per confezionare prodotti granulari sottovuoto
- **Mod. C110: sistema traino-film con 2 assi "servo-motore" e cinghiali "aspiranti"**



		C95e-1	C95e-2
Max film-reel width Max larghezza bobina	mm	520	680
Max film-reel diameter Max diametro bobina	mm	500	500
Bag width Largh. sacchetto	mm	50-240	70-320
Bag length Lungh. sacchetto	mm	50-390	70-470
Mechanical speed up to Velocità meccanica fino a	spr/bpm	100	80
Power consumption Consumo elettrico	kW 50/60Hz	4	4
Air Consumption Consumo pneumatico	Lt/min with/con 6bar	150	150
Weight Peso	kg	750	850

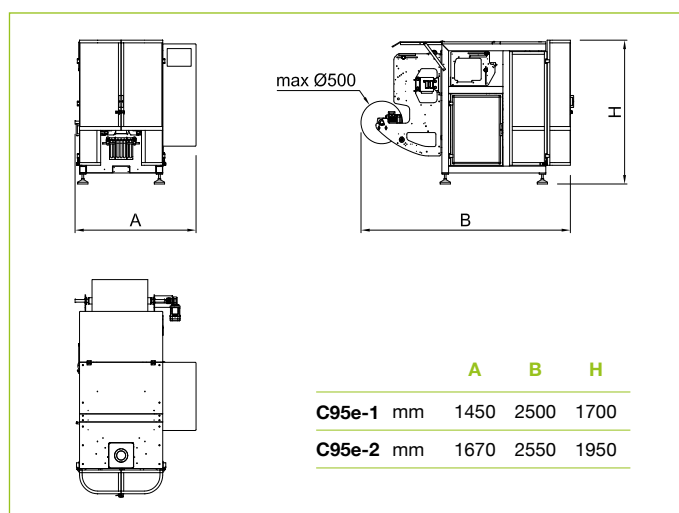

Pillow bag
Sacchetto a cuscino

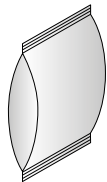

Square bottom bag
Sacchetto a fondo quadro

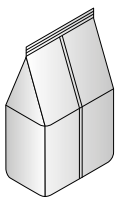

Square bottom bag with off-set vertical seal
Sacchetto a fondo quadro con saldatura verticale laterale

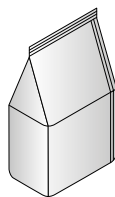

Four-edges sealing bag
Sacchetto a 4 saldature

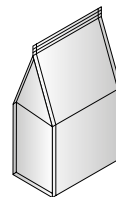

Pillow bag euroslot
Sacchetto a cuscino euroslot

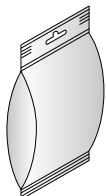

Bag with 3 holes/handle
Sacchetto con 3 fori/maniglia

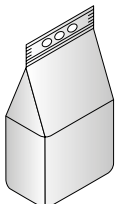

Square bottom/top bag
Sacchetto con fondo e top quadri

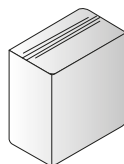

Doy bag
Sacchetto doy bag

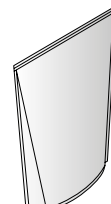

CAMPAGNOLO s.r.l.
Via I° Maggio, 18 - 35015 GALLIERA VENETA (PD) ITALY
Tel. (+39) 049 5965209 - Fax (+39) 049 5965383
info@campagnolo.net - www.campagnolo.net